

## MODEL B TWO POSITION, 4-WAY, PUMP-MOUNTED, AIR-OPERATED VALVE ASSEMBLY

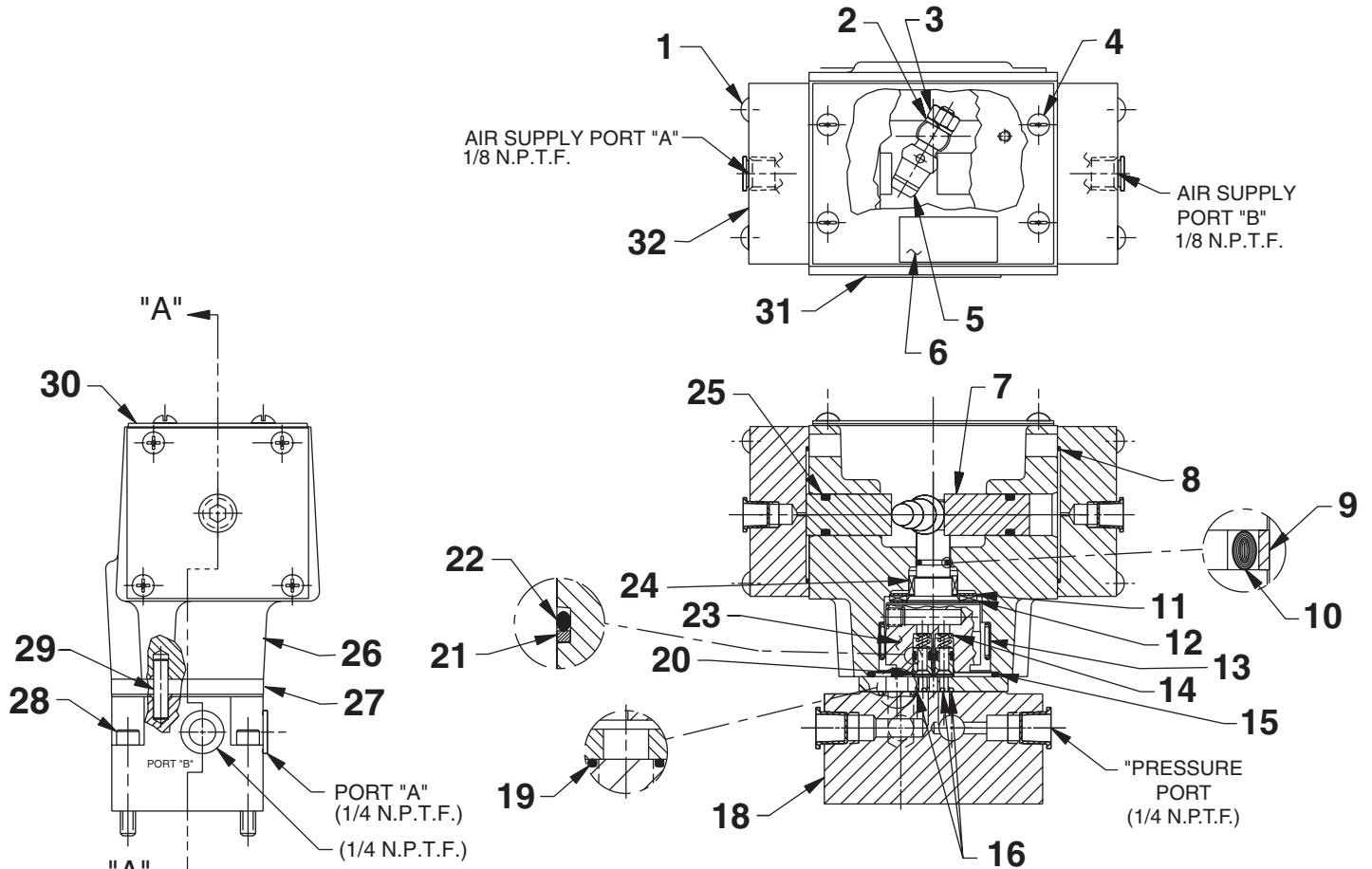

SECTION "A"- "A"

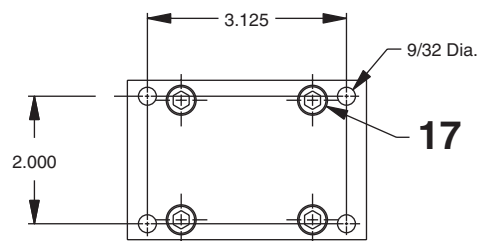

MOUNTING HOLE DIMENSIONS

Refer to any operating instructions included with the product for detailed information about operation, testing, disassembly, and preventive maintenance.

Items found in this parts list have been carefully tested and selected.  
**Therefore: Use only genuine Power Team replacement parts!**

Additional questions can be directed to our Technical Services Department.

# Parts List, Form No. 108078, Back sheet 1 of 1

Item No.	Part No.	No. Req'd	Description	Item No.	Part No.	No. Req'd	Description
1	*13025	8	Rnd. Hd. Screw (8-32 x 1-1/4 Lg.; Torque to 12/14 in. lbs.)	20	303935	2	Shear Seal
2	10245	1	Lockwasher (For 1/4" bolt)	21	*15174	2	Backup Washer (5/16 x 3/16 x 3/64)
3	15504	1	Locknut	22	*10265	2	O-ring (5/16 x 3/16 x 1/16; Nitrile)
4	10164	4	Machine Screw (#10-24 UNC x 3/8 Lg.)		11437	2	O-ring (5/16 x 3/16 x 1/16; Viton)
5	304030	1	Lever (Lubricate at assembly)		17714	2	O-ring (5/16 x 3/16 x 1/16; EPR)
6	209383	1	Patent Decal	23	52064	1	Rotor
7	208673	2	Cam Plunger (Lubricate at assembly)	24	208671	1	Needle Roller Bearing
8	*14852	2	O-ring (1.56 x 1.37 Nitrile)	25	*210230	2	O-ring (2.18 x 2.00 Urethane)
9	*208672	1	Glyd Ring	26	61077	1	Valve Body
10	*10268	1	O-ring (1/2 x 3/8 x 1/16; Nitrile)	27	421896	1	Subplate
	11439	1	O-ring (1/2 x 3/8 x 1/16; Viton)	28	10022	4	Soc. Hd. Machine Screw (1/4-20 UNC x 1-1/2 Lg.; Note When using this valve on a PE30 Series pump order (4) 12001 Screws for mounting valve to pump.)
	17716	1	O-ring (1/2 x 3/8 x 1/16; EPR)				
11	15935	2	Thrust Washer	29	252309	1	Spring Pin
12	12188	1	Roller Bearing	30	303976	1	Cover
13	17505	1	Needle Roller Bearing	31	352038	1	Trade Name Decal (For 9611)
14	15095	2	Compression Spring (1/4 O.D. x 15/32 Lg.)		352039	1	Trade Name Decal (For 9595)
15	*214699	1	O-ring (2-3/16 x 2" x 3/32; Urethane)	32	45209	1	Air Cap
	19017	1	O-ring (Viton)				
	250400	1	O-ring (EPR)				
16	*15023	3	O-ring (5/16 x 3/16 x 1/16; Urethane)				
	11437	3	O-ring (5/16 x 3/16 x 1/16; Viton)				
	17714	3	O-ring (5/16 x 3/16 x 1/16; EPR)				
17	252308	2	Soc. Hd. Cap Screw (5/16-18 x 2-1/4 Lg.; Torque to 170/180 in. lbs.)				
18	66213	1	Subplate				
19	*16164	1	O-ring (.63 x .50 Urethane)				
	11440	1	O-ring (.63 x .50 Viton)				
	12399	1	O-ring (.63 x .50 EPR)				

### PARTS INCLUDED BUT NOT SHOWN

9689	2	Straight Fitting	} For 9595
16797	2	90° Elbow Fitting	
21570	1	Check Valve	} For 9611
206330	1	Check Valve	
16797	1	90° Elbow Fitting	

Part numbers marked with an asterisk (\*) are contained in Repair Kit No. 300332.

## SPECIFICATIONS

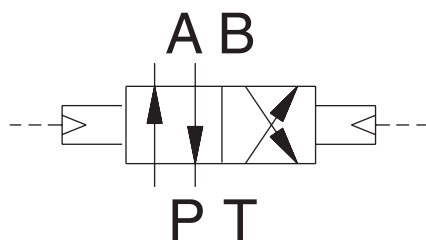

UNIT SCHEMATIC

2-POSITION, 4-WAY  
AIR OPERATED (65 PSI MIN. / 150 PSI MAX.)  
PUMP MOUNTED

RATED PRESSURE = 10,000 P.S.I.  
RATED CASE PRESSURE = 1,000 P.S.I.  
RATED FLOW = 5 G.P.M.

### FUNCTION:

"A" POSITION: (AIR PORT "A")  
HYD. PRESSURE TO "A" PORT,  
"B" PORT TO TANK.

"B" POSITION: (AIR PORT "B")  
HYD. PRESSURE TO "B" PORT,  
"A" PORT TO TANK.

### NOTE:

ALL PORTS OPEN TO TANK DURING  
TRANSITION BETWEEN VALVE POSITIONS.