

CONVERSION KIT

Converts Hydraulic Hand Operated Pumps to Foot Pump Operation
For Model B Pumps

PARTS LIST

| Item No. | Part No. | No. Req'd | Description |
|----------|----------|-----------|---------------------|
| 1 | 53109OR9 | 1 | Foot Lever Assembly |
| 2 | 47374 | 1 | Spring |
| 3 | 214884 | 2 | Spring Retainer |
| 4 | 211743 | 4 | Retaining Ring |
| 5 | 308588 | 1 | Handle Holder |
| 6 | 214883 | 1 | Pin (3-7/16" Lg.) |

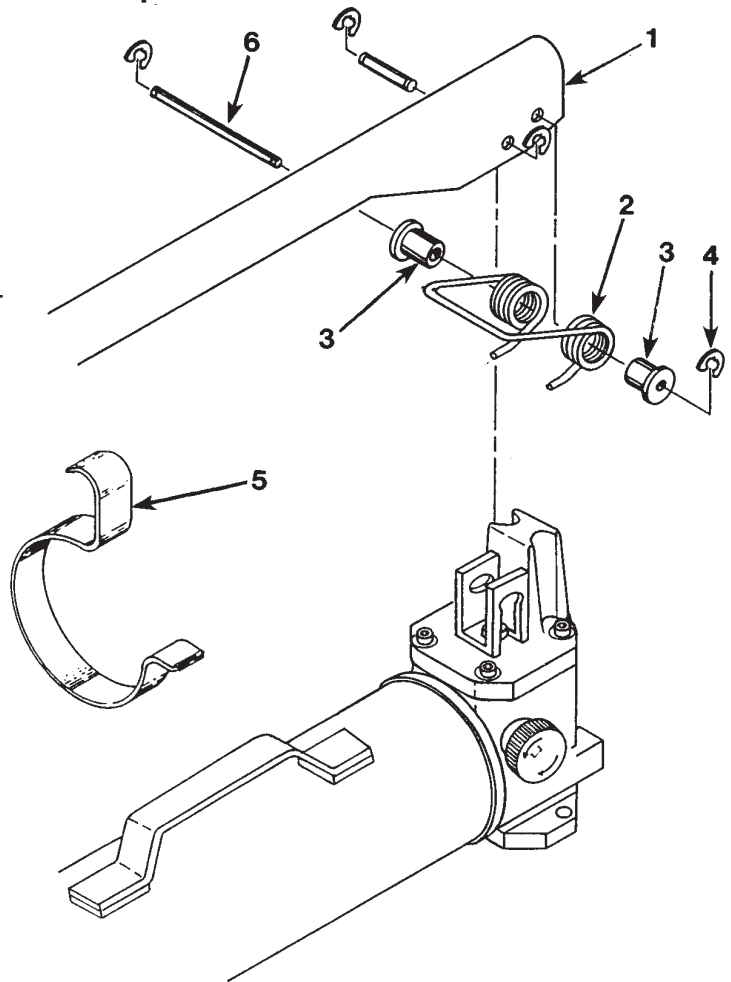

DISASSEMBLY of the HAND PUMP HANDLE

1. Clean the exterior of the pump before beginning the disassembly procedure. With the pump on a clean work surface, continue with the following disassembly steps.
IMPORTANT: Do not damage the piston or allow any contamination to enter the pump since this could cause pump failure.
2. Remove one of the retaining rings on the front pin of the handle assembly. Slide the pin out.
3. Remove both retaining rings from the other pin and slide it out. Remove the handle.

Note: Removed Item #7 from parts list.

Sheet No. 1 of 1

Rev. 1 Date: 10 Sept. 1998

ASSEMBLING the FOOT LEVER to the PUMP

1. Position the spring under the foot lever assembly (see Figure 1), and align the holes of the spring with the holes of the foot lever.
2. Position the foot lever and spring over the protrusion in the pump body cap. Align hole in protrusion with those of the spring. Lubricate the long pin (#214883) provided with the conversion kit and slide it through the spring, foot lever and pump body cap protrusion. Place a spring retainer over each end of the pin and slide them into the spring. Place a retaining ring on each end of the pin.
3. Connect the foot lever to the piston by placing one of the pins removed earlier through the other holes in the foot lever and the piston clip. Replace the retaining ring.
4. Attach the handle holder over the reservoir as shown in Figure 2 and secure the foot lever in it.

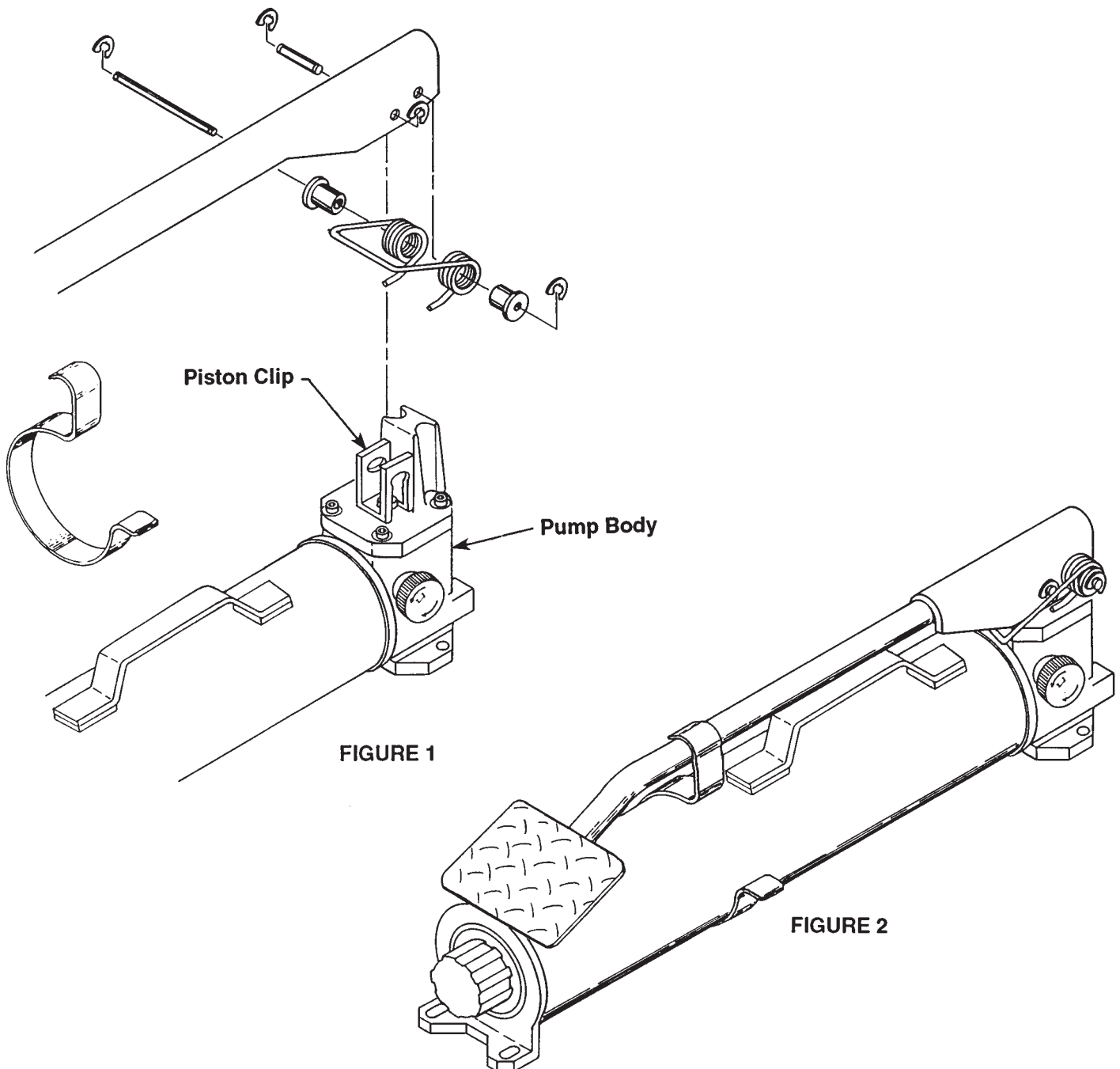

FIGURE 1

FIGURE 2