

**DIGITAL MICROPROCESSOR-BASED PRESSURE GAUGE**  
DG100 OPERATES FROM 0 TO 10,000 PSI  
DG100B OPERATES FROM 0 TO 690 BAR

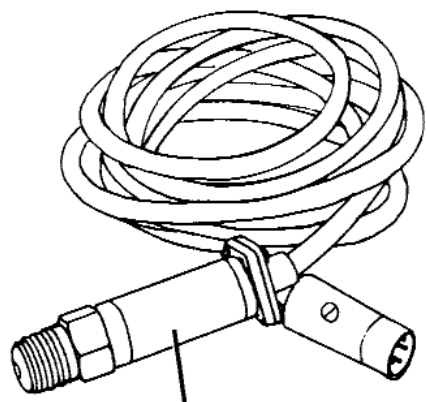

Pressure Transducer  
& Cable Assembly  
#350814

Digital Display  
Pressure Gauge  
Unit

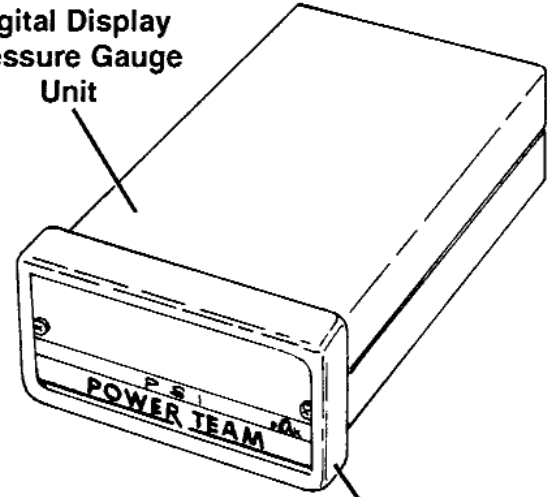

Gauge Protector  
#350818

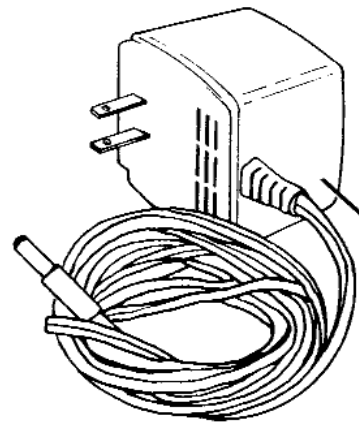

120 VAC/9 V DC  
Power Supply  
#251426

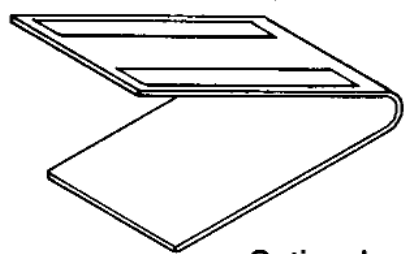

Optional  
Gauge Stand  
#420778

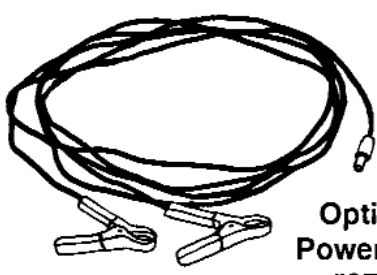

Optional  
Power Cord  
#37045

## SAFETY PRECAUTIONS

- ! WARNING:** To help avoid personal injury,
- All connections must be tightened with proper tools. Do not overtighten. Connections need only be tightened securely and leak-free. Overtightening may cause premature thread failure or may cause high pressure fittings to split at pressures lower than their rated capacities.
  - Should a hydraulic hose or fitting ever rupture, burst, or need to be disconnected, immediately release all pressure. Never attempt to stop a leak under pressure with your hands. The force of escaping hydraulic fluid could cause serious injury.
  - Periodically inspect this unit and all components of the hydraulic system for signs of wear. Inspect all threads and fittings for signs of wear or damage and replace as needed. Clean all hose ends, couplers, or union ends.
  - Always use the proper voltage. Before applying power, inspect all connections and equipment. Repair or replace equipment as required.

## SET-UP

### NOTE:

- Operating temperature range for the electronic display is 0 to 140 degrees fahrenheit (-17 to 60 celsius).
- Operating temperature range for the transducer is -20 to 180 degrees fahrenheit (-29 to 83 celsius).
- Accuracy of the DG100 series Digital Pressure Gauge is +/-1% full scale. Each gauge unit is provided with a pressure transducer that the display was calibrated with. A transducer from one Digital Pressure Gauge cannot be used with accuracy with another display unit without first calibrating the display unit to that transducer.

Connect the DG100 series gauges as follows:  
Refer to Figure 1.

1. Connect the 1/4" NPTF male threaded end of the pressure transducer cable (#350814) to a pressure port on the hydraulic system to be monitored.
2. Connect the male half of the DIN connector on the pressure transducer cable (#350814) to the female half of the DIN connector in the back of the DG100 gauge.
3. Connect the power cord to the power jack in the back of the DG100 gauge and into a suitable power source.

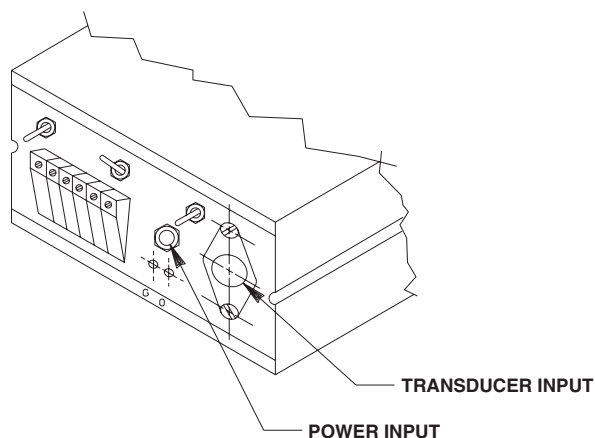

Figure 1

## OPERATION

1. Whenever power is first applied to the gauge, the display will scroll all characters while the gauge runs a self-diagnostics test. A value of zero (0) will be displayed when the diagnostics is complete. 120 VAC 50/60 cycles is required for power supply #251426. A 220 VAC to 120 VAC 50/60 cycle voltage converter (VC220) is available as an option.
2. The gauge will track the increase and decrease of pressure as your hydraulic system is operated from zero (0) pressure up to a maximum of 10,000 PSI (690 BAR). If you exceed the maximum pressure rating of your DG100 series gauge (either 10,000 PSI or 690 BAR) the display will begin to flash and display five dashes (-----), indicating an *over range* condition.
3. The display will flash rapidly when the HIGH (over range) alarm is reached or exceeded. The display will flash slowly when the pressure becomes lower than the LOW alarm setting. The lower limit can be adjusted to zero (0) pressure to disable the flashing display at low pressure.

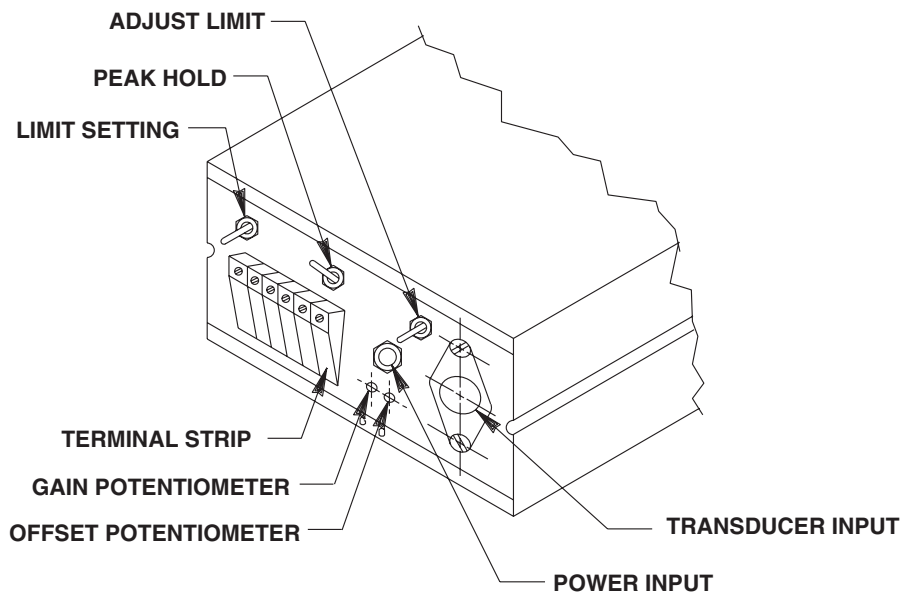

Figure 2

4. The HIGH limit and LOW limit pressure settings can be made by holding the toggle switch labeled LIMIT toward the HI arrow for HIGH limit or LO arrow for the LOW limit. In this mode you will also display the current pressure limit setting for the respective HIGH or LOW limit. While continuing to hold the switch marked LIMIT in the HI or LO mode, press the toggle switch labeled ADJUST LIMIT one direction to increase the respective setting or the other way to decrease that setting. The terminal block is labeled for both the HI limit and the LO limit relay outputs as shown in Figure 2. The center terminal of both the HI limit and the LO limit terminal strip is the common side. Connect the other wire to one side of the respective terminal strip for a normally open switch position or the other side for a normally closed switch position. The relay contacts are rated at 120 VAC and 5 AMPS maximum.
5. To activate the PEAK pressure capture mode, move the toggle switch (labeled PEAK HOLD) to the ON position indicated by the red LED light above the word PEAK on the front of the display (see Figure 3). When the PEAK pressure LED is on, the unit will continue to capture and display the highest pressure value the circuit reads until the PEAK HOLD toggle switch is placed in the OFF position or when power is removed from the gauge unit.
6. The openings labeled "G" and "O" are for GAIN and OFFSET (see Figures 2 & 4). These settings are used at the factory during the calibration of the display with its pressure transducer and will be plugged after these adjustments. The "G" and "O" openings should not be altered in any way as it will affect the accuracy of the gauge. **Note: If calibration adjustments of the display are necessary, see sheet 2 of 2.**

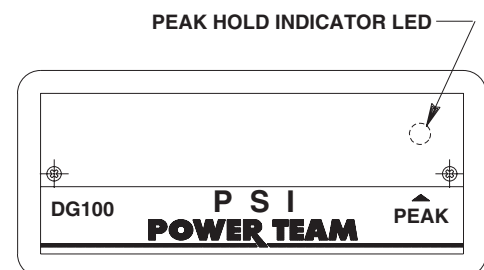
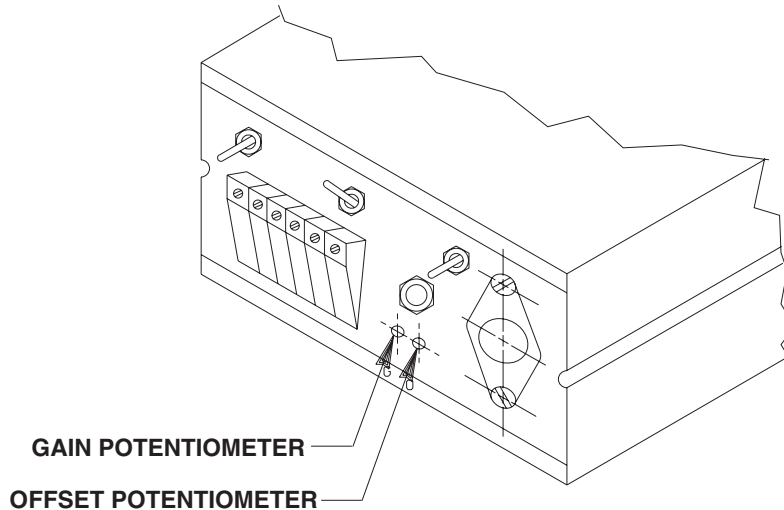

Figure 3

## PROPER CALIBRATION OF A DG100 SERIES DIGITAL PRESSURE GAUGE

To properly calibrate a DG100 series Digital Pressure Gauge, it will be necessary that a calibration device such as a dead weight tester be used and that the calibration device have accuracy traceable to the National Bureau of Standards. For a recalibrated DG100 Digital Pressure Gauge to display accurate readings across its entire pressure range, all adjustment procedure steps must be followed. Refer to Figure 4 for location of the adjustment



potentiometers. Pressure transducers cannot be replaced or exchanged without re-calibrating the display. Contact the factory or your nearest Power Team Authorized Hydraulic Service Center.

**Figure 4**

1. With the display unit properly connected and turned on, apply zero (0) pressure and set the OFFSET (“O”) adjustment potentiometer until the display reads a steady zero (0). **IMPORTANT: Do not adjust this so high that 10 (or 1) occasionally display and do not adjust so low that the gauge becomes inaccurate at the lower pressures.**
2. Apply 10,000 PSI (690 BAR) carefully with the dead weight tester and adjust the GAIN (“G”) potentiometer to just after 9990 PSI (689 BAR). The display will begin to flash and display five dashes (-----), indicating that 10,000 PSI has been reached.
3. Slowly drop pressure to zero (0) and check that the display reads zero (0) and does not display 10 (or 1) occasionally.
4. Apply 1,000, 5,000 and 9,000 PSI (69, 345 and 621 BAR) with the dead weight tester. These pressures should display  $\pm 1\%$  full scale. If not, readjust or contact the factory. **Note: Adjusting the OFFSET (“O”) and GAIN (“G”) affects all readings, so must be set as accurately as possible.**