

Parts List for:

- 9512
- 9513
- 9516
- 9519
- 64749

**MODEL B**  
**SOLENOID CONTROLLED, PILOT OPERATED, 3-POSITION, 4-WAY**  
**VALVE ASSEMBLY**

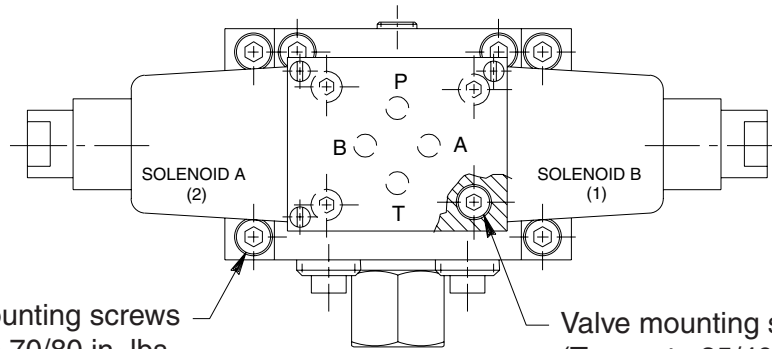

1/4-20 mounting screws  
(Torque to 70/80 in. lbs.  
on pump assembly)

Valve mounting screws  
(Torque to 35/40 in. lbs.)

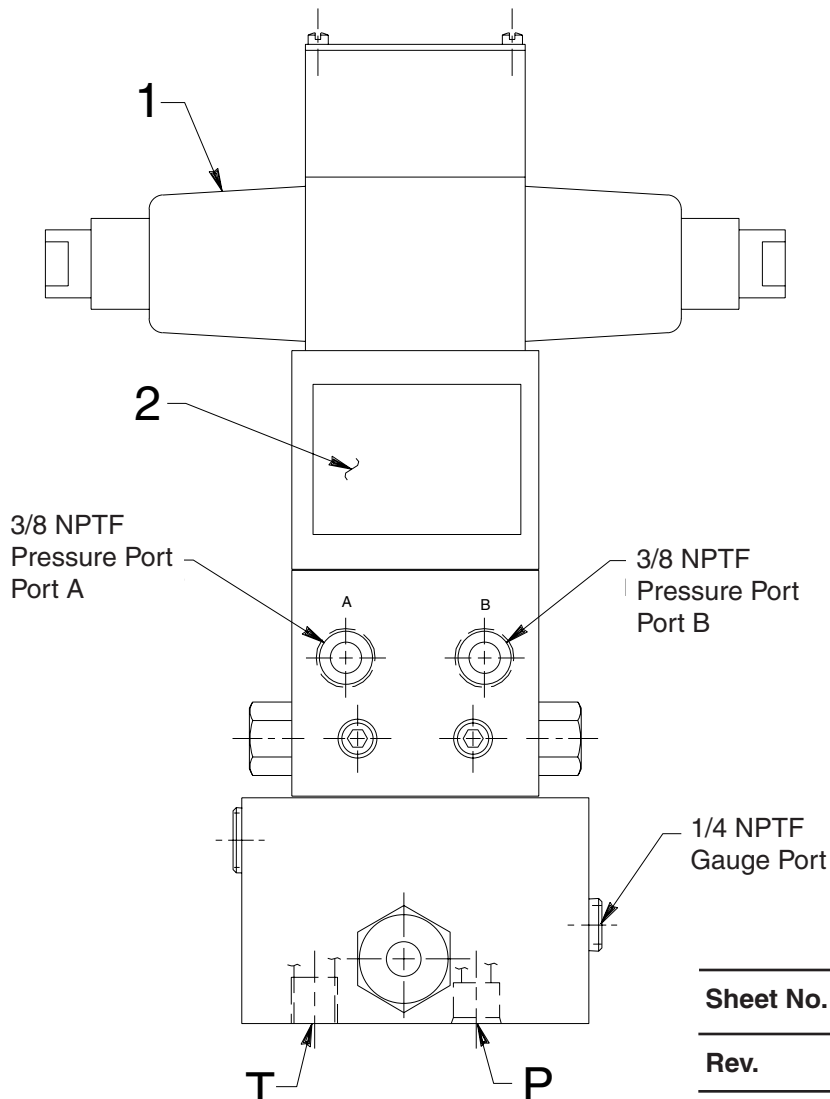

Item No.	Part No.	No. Req'd	Description
1	16664-4	1	Solenoid Valve (24 V., For 9512)
	16664-1	1	Solenoid Valve (115 V., For 9513)
	16664-2	1	Solenoid Valve (230 V., For 9519)
	420417	1	Solenoid Valve (12 Volt DC, For 9516)
2	251690	1	Identification Decal (For 9512)
	251691	1	Identification Decal (For 9513)
	251693	1	Identification Decal (For 9516)
	251694	1	Identification Decal (For 9519)



### HYDRAULIC SCHEMATIC

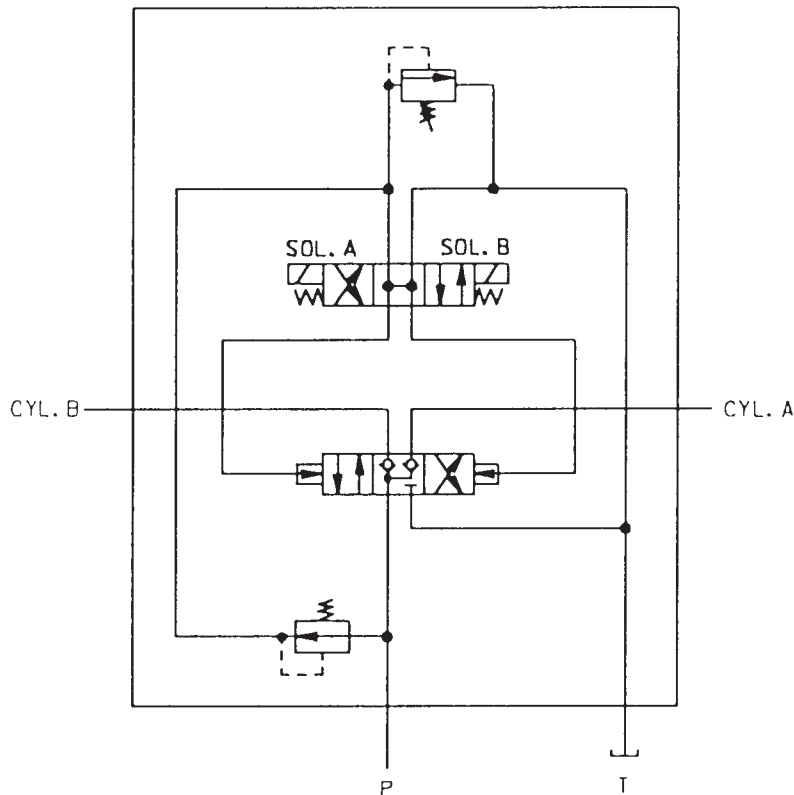

### OPERATION

**Neutral (Hold):** When both solenoids are de-energized, oil from pump circulates at free flow from the pressure port "P" to tank "T". Both cylinder ports are blocked.

**Solenoid "A" Energized:** Pressure to cylinder port "A". Cylinder port "B" to tank.

**Solenoid "B" Energized:** Pressure to cylinder port "B". Cylinder port "A" to tank.

**NOTE:** Pressure holds without loss when shifted from cylinder port to the neutral (Hold) position.

### SIMPLIFIED SYMBOL

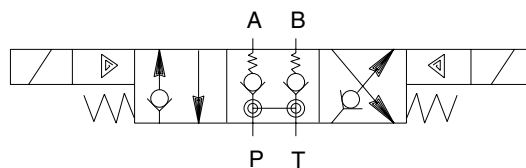

Refer to any operating instructions included with this product for detailed information about operation, testing, disassembly, reassembly, and preventive maintenance.

Items found in this parts list have been carefully tested and selected. **Therefore: Use only genuine replacement parts!**

Additional questions can be directed to our Technical Services Department.

### TOP VIEW & SECTION A-A

Note: Install to bottom of threads. Plug must be below surface (2 places).

To Parts List

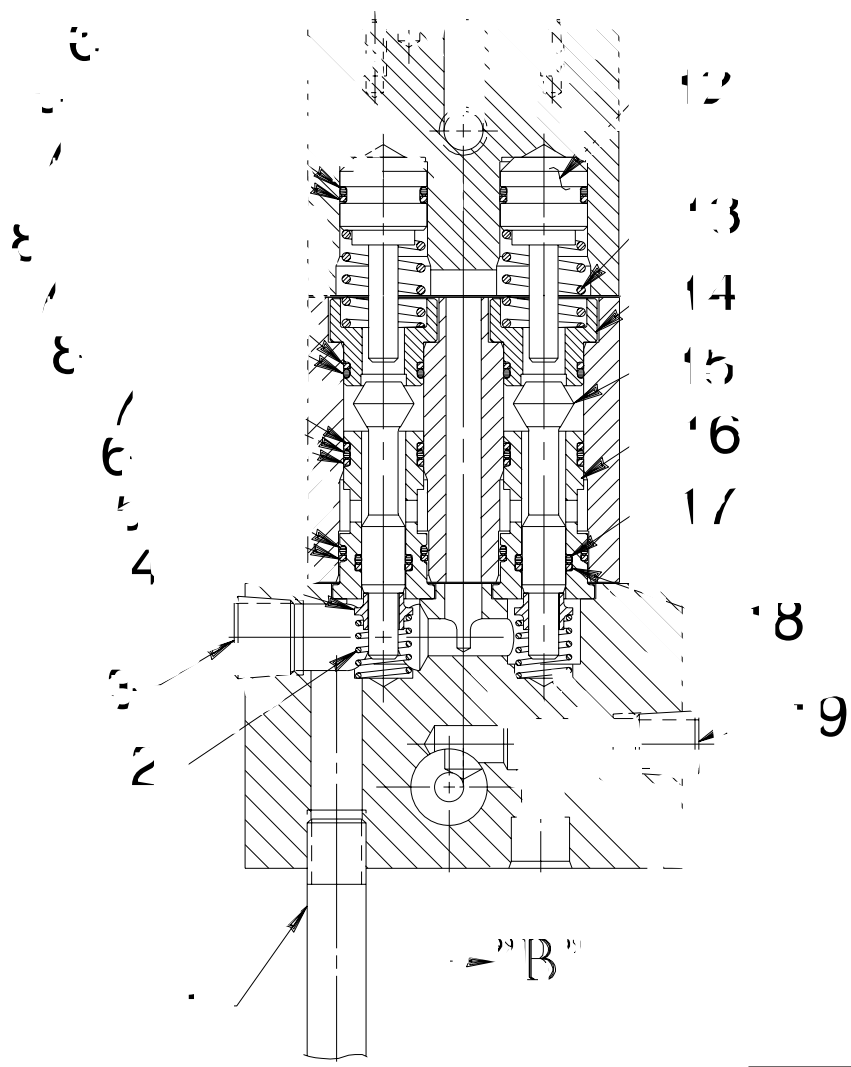
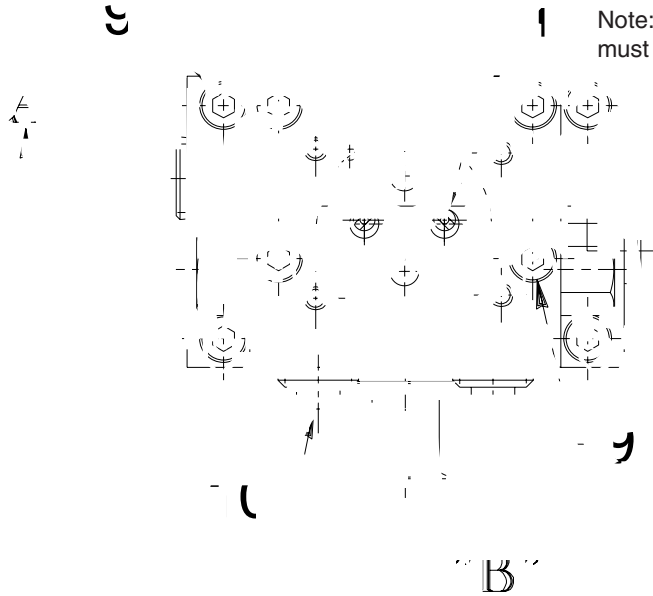

**Parts List, Form No. 101458, Back sheet 2 of 3**

<b>Item No.</b>	<b>Part No.</b>	<b>No. Req'd</b>	<b>Description</b>
1	<b>200609</b>	1	Drain Tube
2	<b>11195</b>	2	Compression Spring (1/2 O.D. X 3/4 Lg.)
3	<b>10909</b>	1	Plug (3/8 NPTF)
4	<b>202479</b>	2	Check Valve Spring Guide
5	<b>*12392</b>	5	Backup Washer (3/4 X 5/8 X 3/64, -016)
6	<b>*10302</b>	5	O-ring (3/4 X 5/8 X 1/16, -016; Nitrile)
	<b>11442</b>	5	O-ring (3/4 X 5/8 X 1/16, -016; Viton)
	<b>12400</b>	5	O-ring (3/4 X 5/8 X 1/16, -016; EPR)
7	<b>*12391</b>	8	Backup Washer (11/16 X 9/16 X 3/64, -015)
8	<b>*11284</b>	5	O-ring (11/16 X 9/16 X 1/16, -015; Nitrile)
	<b>11441</b>	5	O-ring (11/16 X 9/16 X 1/16, -015; Viton)
	<b>250137</b>	5	O-ring (11/16 X 9/16 X 1/16, -015; EPR)
9	<b>10856</b>	8	Cap Screw (1/4-20 X 2-1/2 Lg.; Torque to 200/230 in. lbs.)
10	<b>11127</b>	2	Plug (3/8 NPTF)
11	<b>251675</b>	2	Orifice Plug (Note: Install to bottom of threads. Plug must be below surface [2 places].)
12	<b>307090</b>	2	Pilot Piston
13	<b>213880</b>	2	Compression Spring (11/16 O.D. X 1" Lg.)
14	<b>307089</b>	2	Valve Seat
15	<b>200542</b>	3	Poppet
16	<b>22068</b>	3	Bushing
17	<b>*10268</b>	2	O-ring (1/2 X 3/8 X 1/16, -012; Nitrile)
	<b>11439</b>	2	O-ring (1/2 X 3/8 X 1/16, -012; Viton)
	<b>17716</b>	2	O-ring (1/2 X 3/8 X 1/16, -012; EPR)
18	<b>*11863</b>	2	Backup Washer (1/2 X 3/8 X 3/64, -012)
19	<b>10479</b>	1	Pipe Plug (1/4 NPTF)

Part numbers marked with an asterisk (\*) are contained in Repair Kit No. 300495.



Note: Shaded areas reflect last revision(s) made to this form.

**SECTION B-B & C-C**

To Parts List

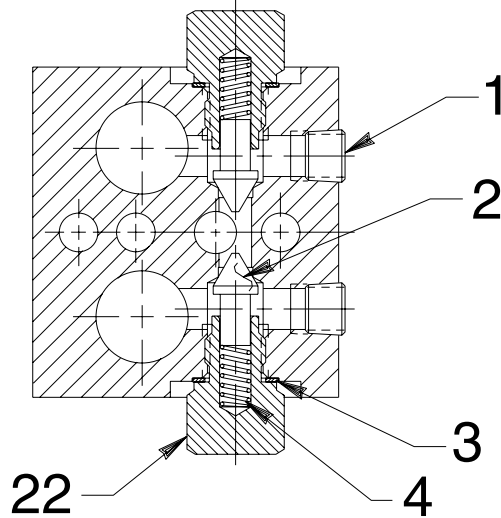

SECTION C-C

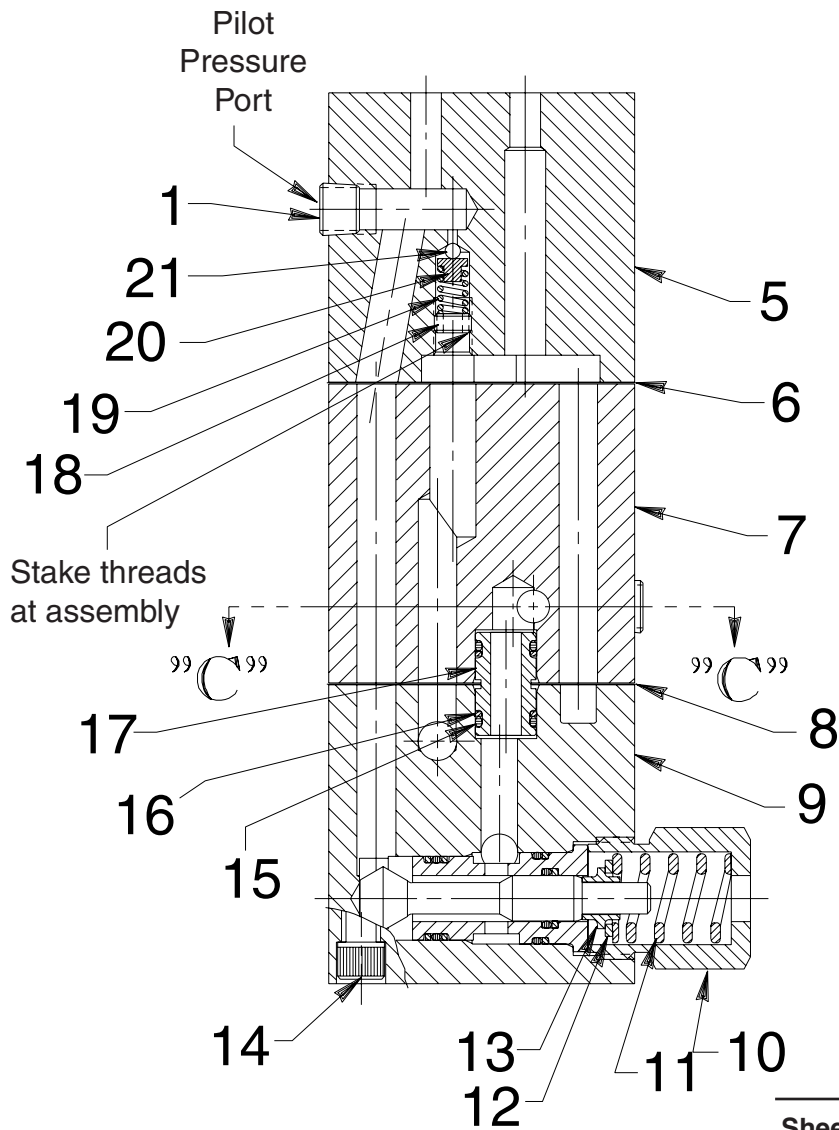

SECTION B-B

# Parts List, Form No. 101458, Back sheet 3 of 3

Item No.	Part No.	No. Req'd	Description
1	10427	3	Pipe Plug (1/8 NPTF)
2	213096	2	Poppet
3	*14874	2	Copper Washer (11/16 X 1/2 X 1/32)
4	15691	2	Compression Spring (1/4 O.D. X 5/8 Lg.)
5	64751	1	Valve Body (Top)
6	*307282	1	Gasket (Top/Center)
7	61529	1	Valve Body (Center)
8	*307579	1	Gasket (Center/Lower)
9	61528	1	Valve Body (Lower)
10	202494	1	Spring Retainer (Torque to 100/125 ft. lbs.)
11	14979	1	Compression Spring (3/4 O.D. X 1" Lg.)
12	16668	1	Washer (5/8 X 3/8 X 1/16)
13	202479	1	Check Valve Spring Guide
14	10856	4	Cap Screw (1/4-20 X 2-1/2 Lg.; Torque to 200/230 in. lbs.)
15	*10268	3	O-ring (1/2 X 3/8 X 1/16, -012; Nitrile)
	11439	3	O-ring (1/2 X 3/8 X 1/16, -012; Viton)
	17716	3	O-ring (1/2 X 3/8 X 1/16, -012; EPR)
16	*11863	3	Backup Washer (1/2 X 3/8 X 3/64, -012)
17	21094	1	Bushing
18	16704	1	Soc. Hd. Jam Screw (5/16-24 UNF X 5/32 Lg.)
19	16665	1	Compression Spring (5/32 I.D. X 1/2 Lg.)
20	202499	1	Spring Guide
21	10418	1	Steel Ball (1/8 dia.)
22	307136	2	Valve Screw (Torque to 35/40 ft. lbs.)

Part numbers marked with an asterisk (\*) are contained in Repair Kit No. 300495.



Note: Shaded areas reflect last revision(s) made to this form.