

**MODEL B  
RESTRICTOR VALVE**  
Max. Capacity: 10,000 PSI

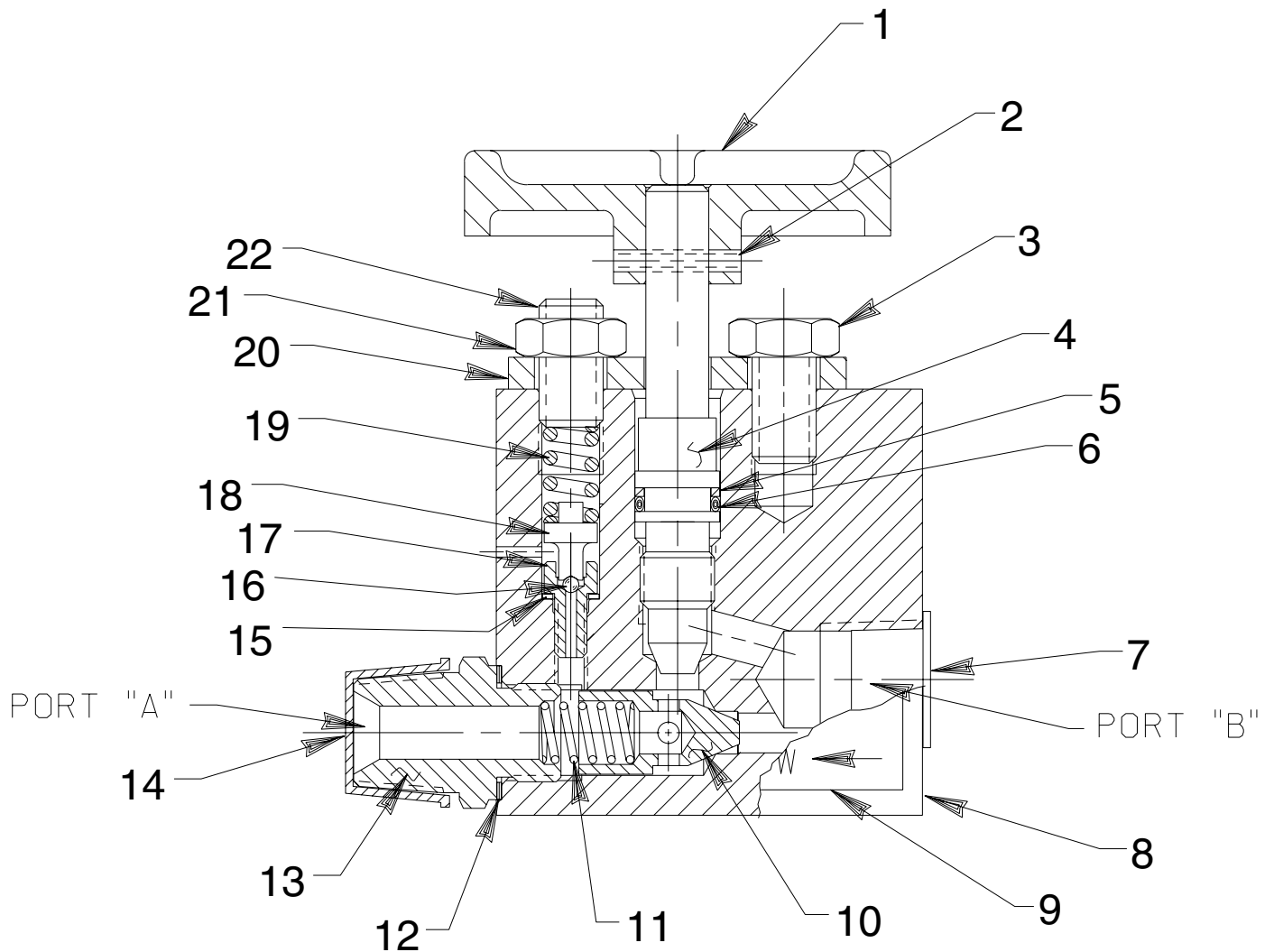

# Parts List, Form No. 100666, Back sheet 1 of 1

Item No.	Part No.	No. Req'd	Description	Item No.	Part No.	No. Req'd	Description
1	23272	1	Knob	13	20879	1	Connector (Torque to 40/45 ft. lbs.)
2	10895	1	Roll Pin	14	12546	1	Cap
3	250951	1	Hex. Hd. Cap Screw	15	14319	1	Copper Washer (5/16 X 3/16 X 1/32)
4	307022	1	Control Valve Stem	16	17238	1	Ball (3/32 Dia.)
5	11863	1	Backup Washer (1/2 X 3/8 X 1/16, -012)	17	203364	1	Replaceable Seat (Torque to 40/50 in. lbs.)
6	10268	1	O-ring (1/2 X 3/8 X 1/16, -012)	18	29785	1	Ball Retainer
7	12545	1	Plug	19	14475	1	Compression Spring (5/16 O.D. X 5/8 Lg.)
8	52861	1	Valve Body	20	202653	1	Stop Plate
9	212983	1	Trade Name Decal	21	10386	1	Jam Nut (3/8-24 UNF)
10	20771	1	Poppet	22	16732	1	Set Screw
11	10425	1	Compression Spring (3/8 O.D. X 3/4 Lg.)				
12	10261	1	Copper Washer (3/4 X 19/32 X 1/32)				

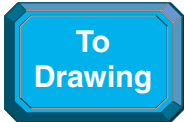

## SPECIFICATIONS

This is a valve that features precision metering for controlled cylinder return and built-in pressure relief. It can be used with either single-acting or double-acting hydraulic cylinders. The valve permits free flow as the ram piston is extended. The built-in check feature automatically locks and holds the load in the raised position until the operator opens the valve. The unit may be preset to provide consistent metered return of the load or the operator may select the rate of return with each actuation.

Male and Female Port Size (in.)	Pressure Relief Setting	Max. Flow Rating	Max. Operating Pressure
3/8 NPTF	12,000 PSI	5 GPM	10,000 PSI

## OPERATION

The direction of free flow is marked on one side of the valve body; note before installing valve.

**Single-acting cylinders:** Connect inline or directly into cylinder port. When valve is closed, free flow is in one direction only. With valve on pumping unit in the retract position the load can then be metered. When load lowering valve is open, operation of the cylinder is normal.

**Double-acting cylinders:** Connect to desired side of cylinder; inline or directly into cylinder port. On double-acting cylinders the load lowering valve should not be completely closed when pressurizing the opposite port.

### NOTE:

- This valve has a built-in safety device that will vent system pressure to atmosphere if accidentally pressurized beyond 12,500 PSI. The maximum capacity for this valve is rated at 10,000 PSI.
- This valve is not recommended for use with a 4-way solenoid valve with a closed center.

